

# A 45W amplifier for 23cm

LDMOS technology offers easy and economical microwave power.

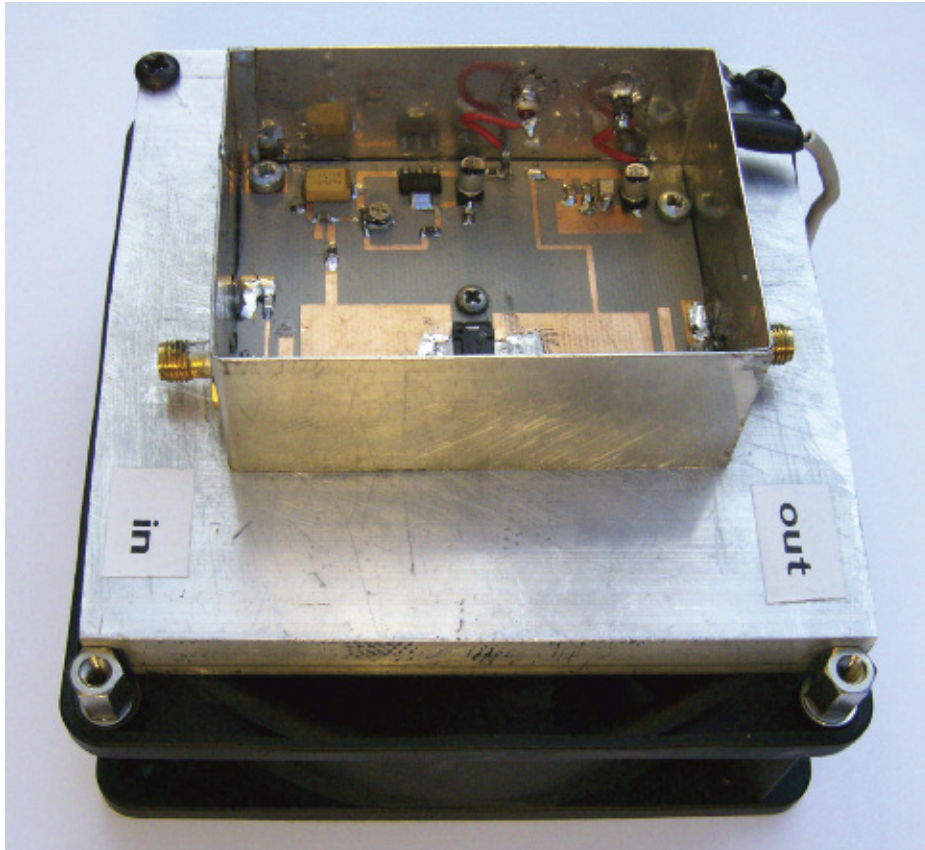

PHOTO 1: A prototype 23cm power amplifier fitted to small aluminium heatsink with fins running horizontally. A small black fan gives enough airflow to keep the heatsink cool (Photo: Colin, G8LBS).

TABLE 1 - COMPONENT LIST

Component	Value	Type	Farnell reference
R1, R3, R4	820Ω	SMD 0805	9334890
R2	10k	SMD preset	1173884
C1, C2, C3	100pF	Np0 ceramic 0805	1414655
C8	47pF	Np0 ceramic 1206	1414734
C11	47pF	Np0 ceramic 0805	1414692
C4, C7	1nF	Np0 ceramic 0805	718567
C5, C9	10μF 35V	SMD electrolytic	8823120
C6	100nF	X7 ceramic 0805	9406387
C10	47μF 16V	SMD electrolytic	498762
U1	MRF9045	LDMOS power FET	www.g4bao.com
U2	TS2937CW	SMD 5V regulator	7261365
TRL1-8		Microstrip matching lines on PCB	

**INTRODUCTION.** For many years I operated on 23cm with just 2 watts RF output but never experienced the aircraft scatter and consistent over-the-horizon contacts that I knew the band could support. Increasing the power by 13dB or so opened up the band in ways I didn't think possible. This article

describes a 45W Class AB Power amplifier covering the 1.3GHz band that requires only a few watts of drive for full output. It is a modern, safe replacement for a single 2C39A valve amplifier and does not require a hazardous high voltage power supply. It is ideal for use with a DB6NT or similar transverter, a Kenwood TS2000X or similar transceiver, reaching a power level where the 1.3GHz band becomes interesting.

The design is very simple and based around a single Freescale [1] MRF9045 28 volt LDMOS device. The PCB is designed to fit in to a readily available 72 x 55 x 30mm tinplate box [2], and should be bolted to a suitable large, heatsink. Alternatively, a

smaller heatsink with a fan can be used, as shown in **Photo 1**. A mini kit consisting of the PCB and MRF9045 is available [3].

This project uses small surface mount devices and requires some experience to construct and set up. It is therefore not suitable for novice constructors.

**CIRCUIT DESCRIPTION.** Researching designs for the MRF9045 and similar devices it seemed that matching these devices to 50Ω at 1.3GHz requires a relatively simple microstrip network with low impedance (ie wide) lines on the input and output. Half a day playing with Appcad [4] and a Smith chart program [5] allowed me to get a reasonable handle on the required matching networks.

**Figure 1** shows the complete circuit diagram. In order to reduce losses, the final circuit avoids using trimmers and shunt capacitors. Device input and output impedances are matched to 50Ω using series low impedance lines TRL2, 4 and 5. 'Shunt' lines facilitate the final tuning. The open circuit shunt lines TRL3, TRL6 perform the function of the shunt capacitors of lumped element designs and there is a short circuited shunt line on the input, TRL1, grounded at the end by C5.

The 28 volt supply is connected to the drain via an isolating quarter wave high impedance line, TRL7 and decoupled over a wide range of frequencies by C3, C4, C5 and C6.

Positive gate bias is fed via a similar high impedance line, TRL8, from a 5V regulator and potential divider to set the standing drain current to 350mA. The gate supply is decoupled by C7, C8 and C10. The connection to the gate is via 'stopper resistor' R1. This is essential to the design, as it vastly improve low frequency stability of the amplifier. LDMOS devices are remarkably robust but they are susceptible to too much gate voltage. The only time I've destroyed a device during development is when I omitted this resistor.

Without gate bias the amplifier takes very little current. Switching the 5V regulator from the press to talk (PTT) line is a convenient way to switch the amplifier in and out of standby, minimising standby power consumption and heat generation.

**CONSTRUCTION.** The PA is built on a special 0.8mm thick low loss Teflon PCB, the

overlay for which is shown in **Figure 2**. I developed the design using RF35 from Taconic Advanced Dielectrics Division in Ireland [6] to whom I gratefully acknowledge the sample of material that allowed the development.

My first attempt at the design, using cheap FR4 material, worked after a fashion, but produced much less power and, more importantly, eventually failed, as the losses in the board caused the output microstrip line to heat up alarmingly and produce smoke after about 5 minutes!

**Table 1** shows the component list for the amplifier. The only really critical component is the 1206 capacitor for the output coupling.

The MRF9045 used in the design is in a TO270 solder-down plastic package. These are now becoming more popular and eliminate the need for hazardous beryllium oxide in the package.

The device is soldered to a piece of copper plate approximately 27mm square and 1mm thick, which acts as a heat spreader between the MRF9045 and the heatsink. (Actually I used one face cut from a piece of waveguide 16). The spreader is soldered to the underside of the PCB and has two holes drilled in it to allow the spreader to be bolted to the heatsink.

Applications note AN1907 [7] from Freescale gives very strict guidelines on temperatures for soldering these devices but I thought, "what the heck, I can't afford a soldering oven, but I can afford to sacrifice a couple of devices if it doesn't work". So I tinned the underside of the PCB, the mating surface of the spreader and the topside where

the drain and gate tabs go, bolted the spreader and PCB tightly together. I then dropped the module, spreader side down, on the kitchen ceramic hob, turned it on and waited for the solder to melt. It duly did, leaving a shallow 'pool' of solder in the rectangular hole in the PCB. I carefully placed the device into the hole, pressing down with the tweezers. I then quickly slid the module off the heat, keeping the pressure on the device until the solder set. Once the device is fitted you can solder in the other components. I have used this technique many times now with no ill effects on the devices. If you have a proper hotplate, all the better; I have now gone 'upmarket', using an old dry clothes iron, that I clamp upside down in a vice; that does the trick just as well.

No special precautions or techniques are required for fitting the other components, apart from good microwave practice. Be particularly careful to avoid excess solder, whiskers or excessive flux residues as these can affect performance.

**ALIGNMENT.** Bolt the assembled board and heat spreader to a large heatsink. The input and output matching tabs are split so that you can lengthen or shorten them by bridging them with solder, if necessary. Start with all the tabs linked for maximum length.

Connect the input from your 1.3GHz transmitter to the amplifier input via a suitable SWR meter.

FIGURE 1: 23cm power amplifier circuit diagram.

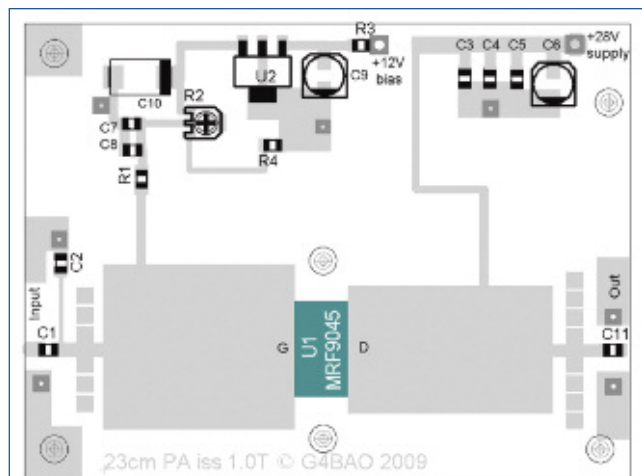
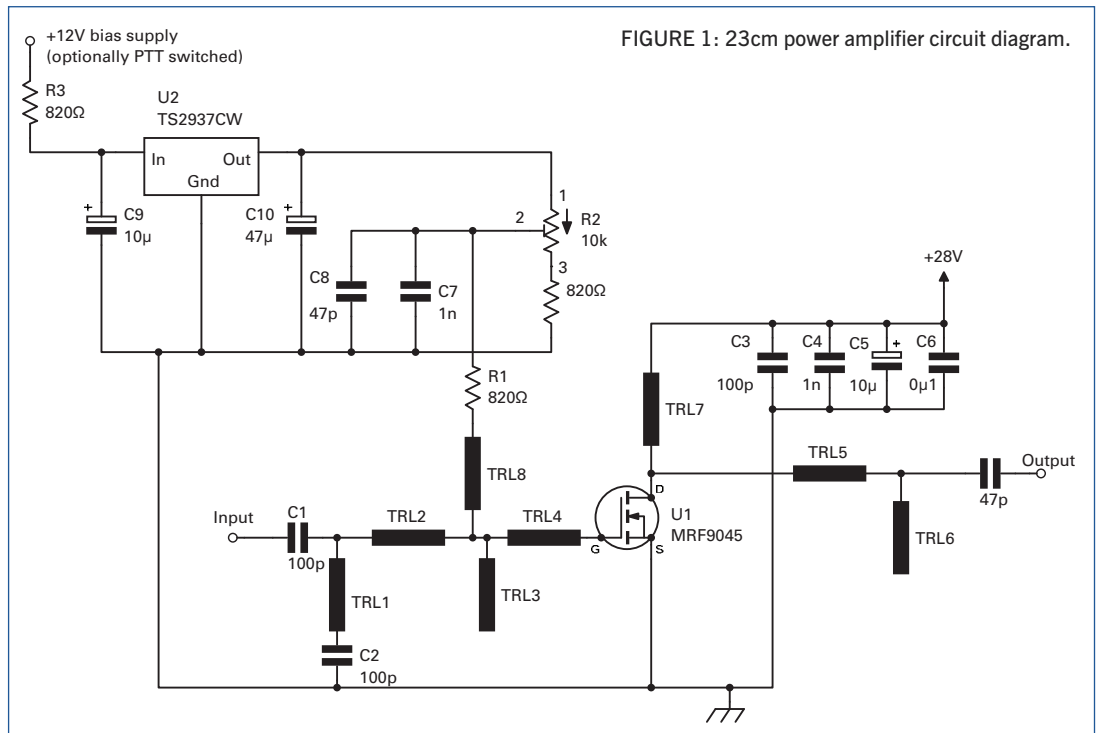

FIGURE 2: PCB overlay.

Connect the amplifier output to a power meter/ dummy load capable of dissipating and measuring at least 50W.

Connect the drain to 28 volts via an ammeter on the 1A range. Connect the gate bias supply, starting with minimum volts on the gate and very carefully increase the gate voltage until the device begins to take current. This onset is very sharp, so be very careful, as the drain current can easily swing up to many amps if you are not careful. Set the drain current to 350mA. Switch off power and then switch the ammeter to the 10A range. Switch back on. Apply 0.5W drive and check the input VSWR. It should be better than about 1.7:1.

If the input VSWR and output power are about right you're finished, so leave well alone! If not, switch off. Remove one section of one input tab at a time until the VSWR is less than 1.7:1 and check the output power and current. If necessary, trim the output tabs in the same way for maximum power. Do NOT try to make these adjustments with the amplifier operating. Turn up the drive in 3dB steps to 2W and check that the power increases about 3dB each time until it saturates. Now trim the output tab for minimum current consistent with maximum output power. It goes without saying, I hope, that you disconnect both the drain and source bias supplies before you trim the tabs.

**RESULTS.** Test results for a prototype amplifier are shown in **Figures 3** and **4**.

**CONCLUSIONS.** This is an inexpensive PA and is relatively easy to build, with readily available components and produces a useful increase in output power for transverters and transceivers.

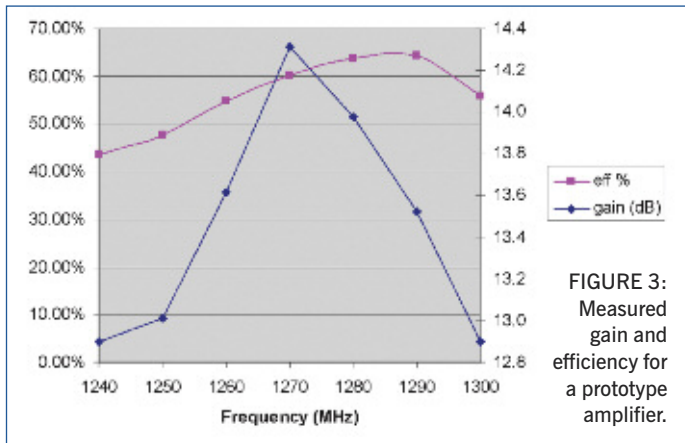

FIGURE 3: Measured gain and efficiency for a prototype amplifier.

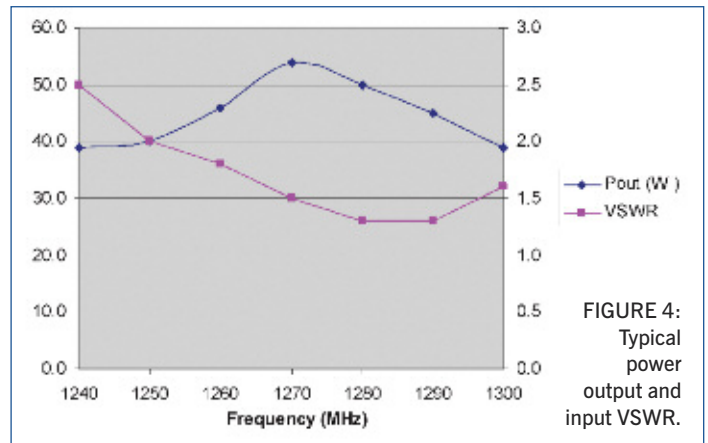

FIGURE 4: Typical power output and input VSWR.

It is efficient and it is safe, in that it does not use any hazardous high voltage supplies. Note, though, it will give you a nasty RF burn if you are silly enough to poke your finger on the output line while transmitting.

It covers the whole of the 1.3GHz narrow band section and, with careful retuning (tabbing), could be adapted to cover the 1240MHz section of the band if band planning eventually forces a move of 1.3GHz narrowband lower in the band.

The amplifier can be made small enough to be masthead mounted, particularly if a fan is fitted, or with a bigger heatsink can be silent for shack use.

**DEVICE AND PCB AVAILABILITY.** A colleague in the US was lucky enough to find a source of 'new old stock' MRF9045 LDMOS power transistors in sufficient quantity to make it possible to offer them to constructors. These devices and a PCB will be available shortly, see [3]. I strongly recommend that you do not attempt to make your own PCB, particularly on FR4 laminate, due to the likelihood of catastrophic board failure.

**REFERENCES**

- [1] Freescale applications note AN1907, [www.freescale.com/files/rf\\_if/doc/app\\_note/AN1907.pdf](http://www.freescale.com/files/rf_if/doc/app_note/AN1907.pdf)

- [2] Suitable tinplate boxes can be obtained from Alan Melia, G3NYK at [www.alan.melia.btinternet.co.uk/componen.htm](http://www.alan.melia.btinternet.co.uk/componen.htm)
- [3] PCBs and MRF9045 devices will be available in Europe from [www.g4bao.com](http://www.g4bao.com), and in the Americas from [www.wa5vjb.com](http://www.wa5vjb.com).
- [4] A free and fully functional copy of 'Appcad' can be downloaded from [www.hp.woodshot.com/appcad/appcad.htm](http://www.hp.woodshot.com/appcad/appcad.htm).
- [5] A demo version of 'Smith' can be downloaded from [www.fritz.dellsperger.net/downloads.htm](http://www.fritz.dellsperger.net/downloads.htm)
- [6] Taconic International, Advanced Dielectrics Division, Mullingar Business Park, Mullingar, Co. Westmeath Tel: 00353 (0) 44 9339071, e-mail: [add@4taconic.com](mailto:add@4taconic.com); [www.taconic-add.com](http://www.taconic-add.com)
- [7] Freescale applications note AN1907, "Solder Reflow Attach Method for High Power RF Devices in Plastic Packages"

**HAM RADIO**



**Europe's No. 1!**

34th International Amateur Radio Exhibition

**June 26–28, 2009**

Messe Friedrichshafen/Germany

in association with the 60th DARC Lake Constance Meeting

- Europe's leading ham radio event
- Presenting the best and the latest from the world of radio, electronics and CB technology

MESSE FRIEDRICHSHAFEN

Fr. to Sat. 9 a.m. – 6 p.m.  
Sun. 9 a.m. – 3 p.m.  
[www.hamradio-friedrichshafen.com](http://www.hamradio-friedrichshafen.com)



DARC  
Deutscher Amateur Radio Club e.V.

www.ttk-werbung.de

...with HAMtronic

...Electronics...Internet...Computer...

# Bluefin

## Fine-tune your Insurance Protection

Radsure from Amateur Radio Insurance Services provides protection for radio amateurs who are serious about their hobby.

A comprehensive package of "all risks" (including breakdown) equipment cover and personal liability cover.

From under £5 a month!

For a quotation, call us now or visit us online.

[www.bluefininsurance.co.uk/amateurradio](http://www.bluefininsurance.co.uk/amateurradio)

020 7335 1648

Please quote Radcom when contacting

Amateur Radio Insurance Services is a trading name of Bluefin Insurance Services Limited. Bluefin Insurance Services Limited is authorised and regulated by the Financial Services Authority.

Corporate Consulting | Financial Advice | Insurance Solutions | Wealth Management

